

OVERVIEW

The SM8121A is a high efficiency step-up DC-DC converter. Due to high voltage CMOS process realizing 25V output supply as maximum value, 2 to 6 lights of white LED connected in series can be lighted. By connecting in series, current variation among LED is eliminated. Current value sent to white LED can be set by external resistors. In addition, brightness can also be adjusted by control to FB pin or CE pin.

FEATURES

- Boost-up control using PWM
- 2 to 6 lights of white LED (connected in series) lighted
- Output current value can be set by external resistors
(51Ω: 9.8mA, 33Ω: 15.2mA, 24Ω: 20.8mA)
- Brightness adjustable by control to FB pin or CE pin
- Current variation among LED decreased by high precision
- High efficient drive by step-up model
- Supply voltage range: 2.3 to 5.5V
- Maximum output voltage: 25V
- Quiescent current: 400μA (typ)
- Standby current: 1.0μA (max)
- R_{ON} (Switching MOS-Tr): 2Ω(typ)
- Switching frequency: 1.0MHz (typ)
- Output current detection accuracy: ±2%
- Small package: SOT23-5 (SM8121AH)

PINOUT

(Top View)

- SOT23-5

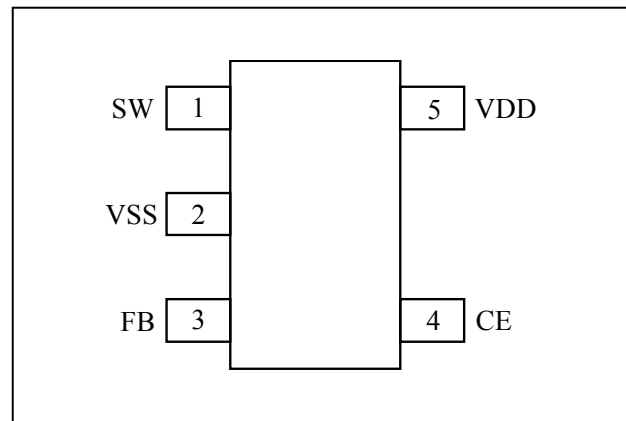

APPLICATIONS

- Cellular phone
- Pager
- Digital still camera
- Handy terminal
- PDAs
- Portable games
- White LED drive
- LCD bias supply
- Flash memory supply

ORDERING INFORMATION

Device	Package
SM8121AH	SOT23-5

PACKAGE DIMENSIONS

(Unit: mm)

■ SOT23-5

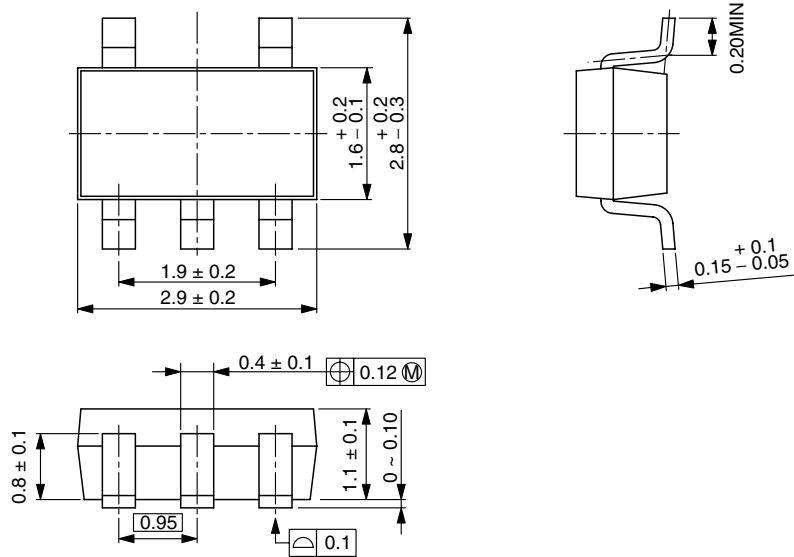

BLOCK DIAGRAM

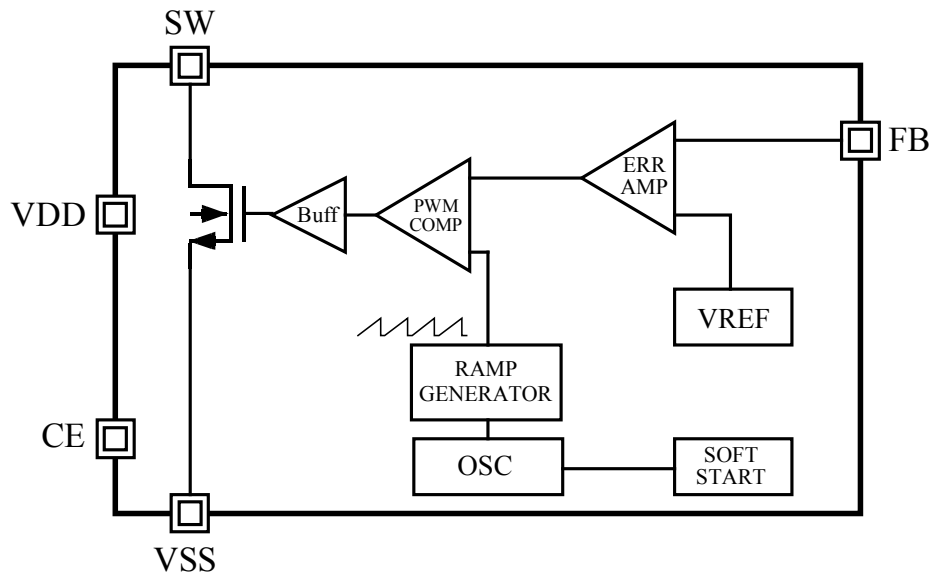

PIN DESCRIPTION

Number	Name	I/O	Description
1	SW	O	Coil switching
2	VSS	-	GND
3	FB	I	Feed back (Output current detection)
4	CE	I _p ^{*1}	Chip enable (High active)
5	VDD	-	Power supply

*1. Input with built-in pull-down resistor

SPECIFICATIONS

Absolute Maximum Ratings

Parameter	Symbol	Rating	Unit
Supply voltage range	V_{DD}	-0.3 to 6.5	V
Input voltage range	V_{IN}	$V_{SS} - 0.3$ to $V_{DD} + 0.3$	V
SW output voltage range	V_{SW}	-0.3 to 27	V
SW input current	I_{SW}	500	mA
Power dissipation	P_D	250 ($T_a = 25^\circ\text{C}$)	mW
Operating temperature range	T_{opr}	-40 to 85	$^\circ\text{C}$
Storage temperature range	T_{stg}	-55 to 125	$^\circ\text{C}$

Electrical Characteristics

$V_{DD} = 3.6\text{V}$, $V_{SS} = 0\text{V}$, $T_a = 25^\circ\text{C}$ unless otherwise noted

Parameter	Pin	Symbol	Condition	Rating			Unit
				min	typ	max	
Supply voltage	VDD	V_{DD}		2.3	3.6	5.5	V
Maximum output voltage	SW	V_{OUT}		-	-	25	V
Standby current	VDD	I_{STB}	$V_{CE} = 0\text{V}$	-	-	1.0	μA
Quiescent current	VDD	I_{DD}	$V_{FB} = 1.0\text{V}$	-	150	300	μA
			$V_{FB} = 0\text{V}$	-	400	800	μA
SW-Tr ON resister	SW	R_{ON}	$I_{SW} = 100\text{mA}$, $V_{DD} = 3.6\text{V}$	-	2.0	3.0	Ω
SW-Tr leak current	SW	I_{LEAK}	$V_{SW} = V_{DD}$	-	-	1.0	μA
Switching frequency	SW	f_{OSC}	$V_{FB} = 0\text{V}$	0.9	1.0	1.1	MHz
Maximum duty	SW	Duty	$V_{FB} = 0\text{V}$	65	75	85	%
Input voltage	CE	V_{IH}		2.0	-	-	V
		V_{IL}		-	-	0.6	V
Input current	CE	I_{CE}	$V_{CE} = 3.6\text{V}$	-	5.0	10	μA
	FB	I_{FB}	$V_{FB} = 0.5\text{V}$	-1.0	-	1.0	μA
Soft-start time	SW	T_{SS}		-	500	-	μs
FB voltage	FB	V_{FB}		0.49	0.50	0.51	V
Coil inductance	SW	L_{SW}		-	-	10	μH

Typical Characteristics

$V_{SS} = 0V$, $T_a = 25^\circ C$ unless otherwise noted

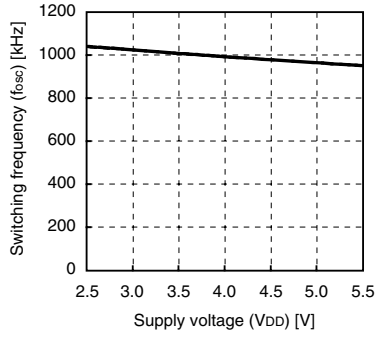

V_{DD} vs. f_{OSC}

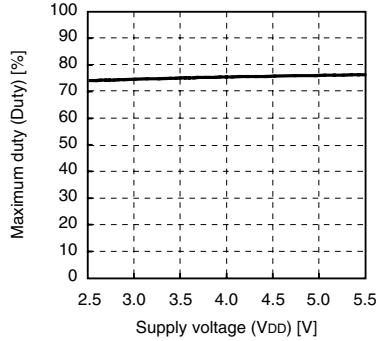

V_{DD} vs. Duty

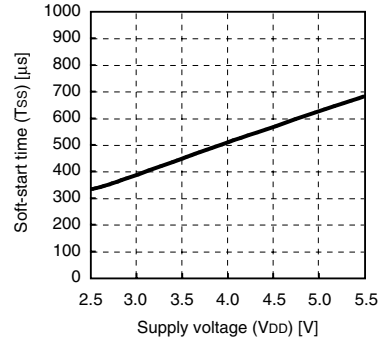

V_{DD} vs. T_{SS}

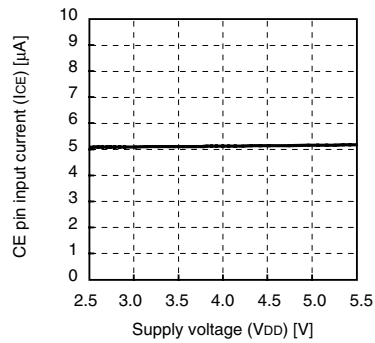

V_{DD} vs. I_{CE} ($V_{CE} = V_{DD}$)

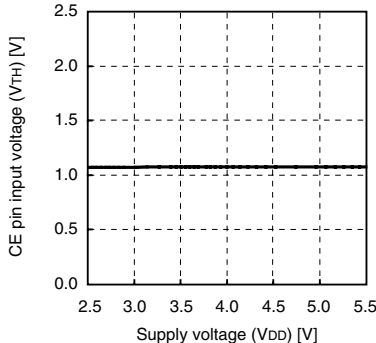

V_{DD} vs. V_{TH}

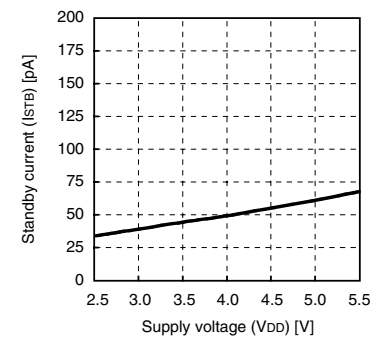

V_{DD} vs. I_{STB} ($V_{CE} = 0V$)

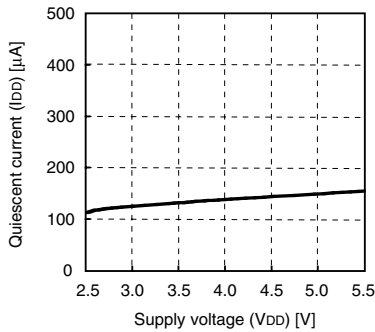

V_{DD} vs. I_{DD} ($V_{FB} = 1.0V$)

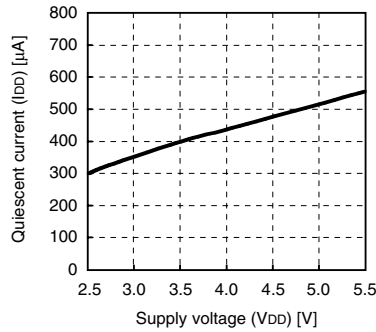

V_{DD} vs. I_{DD} ($V_{FB} = 0V$)

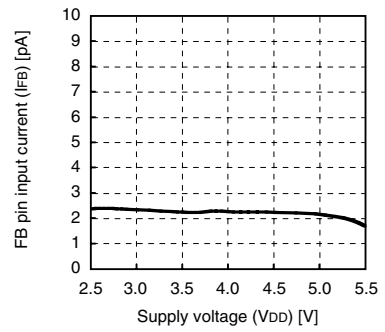

V_{DD} vs. I_{FB} ($V_{FB} = 0.5V$)

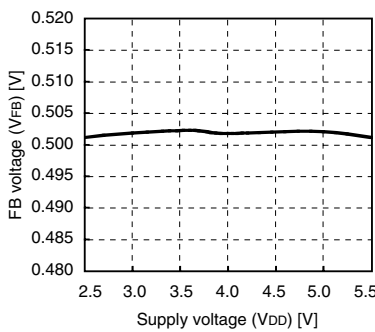

V_{DD} vs. V_{FB}

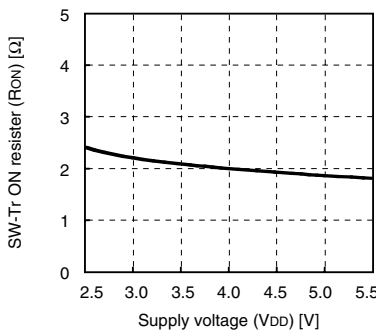

V_{DD} vs. R_{ON}

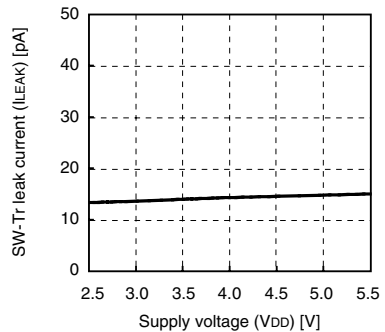

V_{DD} vs. I_{LEAK}

SM8121A

$V_{DD} = 3.6V$, $V_{SS} = 0V$ unless otherwise noted

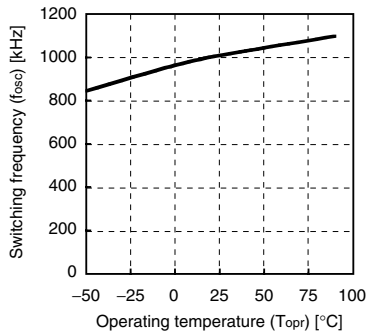

T_{opr} vs. f_{osc}

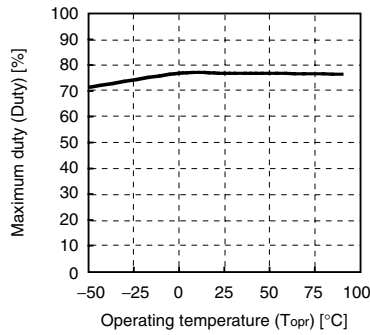

T_{opr} vs. Duty

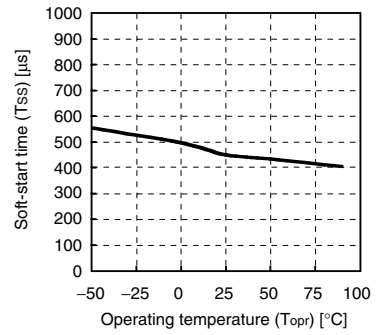

T_{opr} vs. T_{ss}

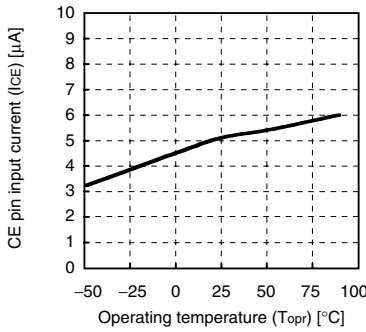

T_{opr} vs. I_{CE} ($V_{CE} = V_{DD}$)

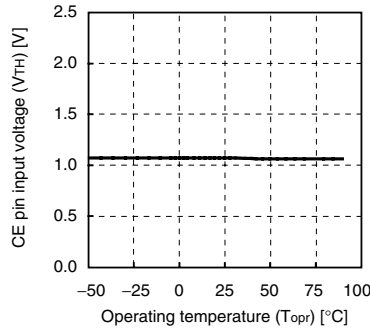

T_{opr} vs. V_{TH}

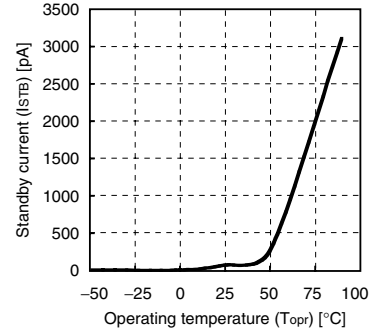

T_{opr} vs. I_{STB} ($V_{CE} = 0V$)

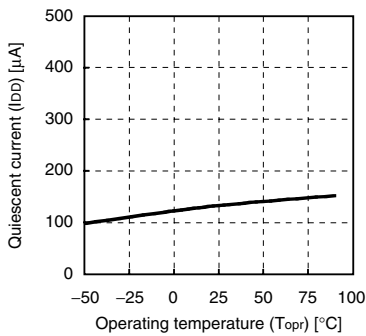

T_{opr} vs. I_{DD} ($V_{FB} = 1.0V$)

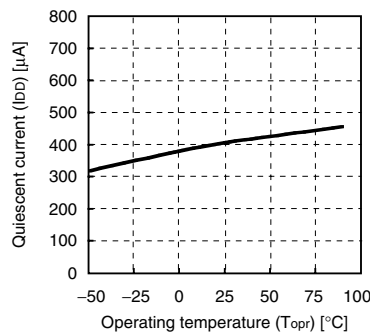

T_{opr} vs. I_{DD} ($V_{FB} = 0V$)

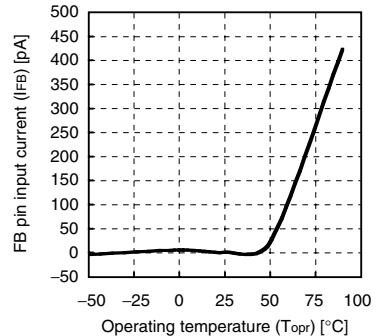

T_{opr} vs. I_{FB} ($V_{FB} = 0.5V$)

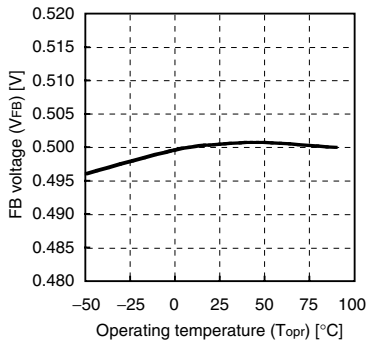

T_{opr} vs. V_{FB}

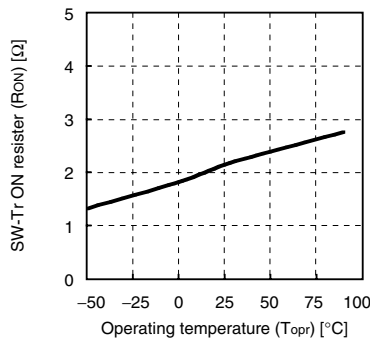

T_{opr} vs. R_{ON}

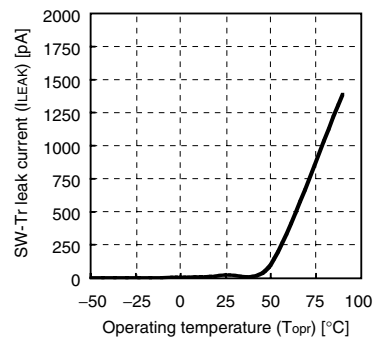

T_{opr} vs. I_{LEAK}

OPERATION OVERVIEW

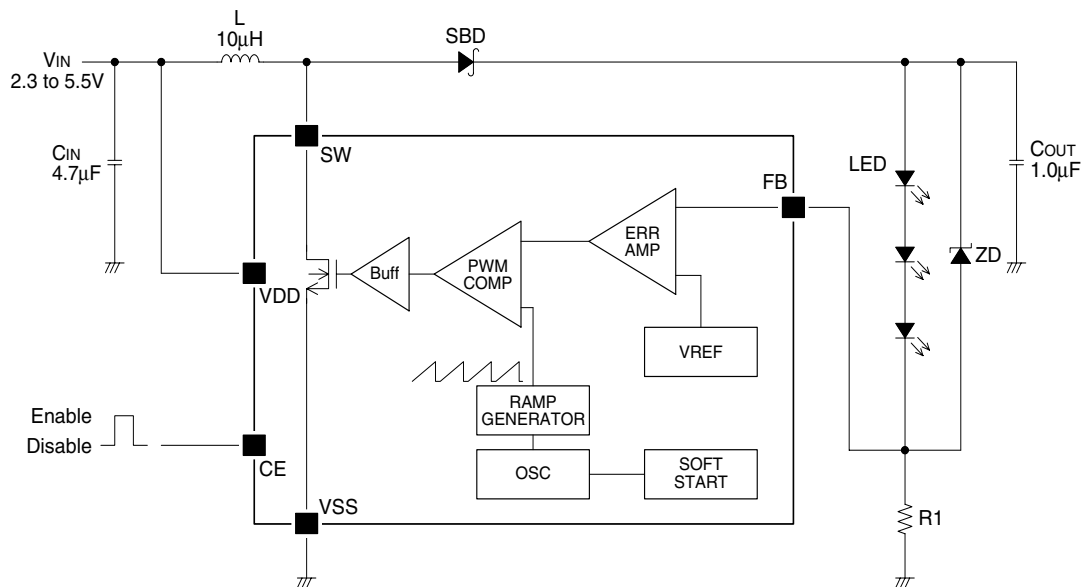

The SM8121A basic structure is a step-up DC/DC converter. The booster control employs Pulse Width Modulation (PWM) which controls the pulse duty cycle (75% max.) at constant frequency (1.0MHz typ.). The LED current is set by a current-setting resistor R1 connected between pins FB (with stable voltage of 0.5V typ.) and VSS.

When the switching transistor SW-Tr is ON, energy is stored in the inductor L. When SW-Tr is rapidly switched OFF, the energy stored in the inductor generates a voltage across the terminals of the inductor. The induced voltage, after being added to the input voltage, turns ON the Schottky barrier diode SBD and the stored energy is transferred to the output capacitor. This sequence of events continues repeatedly, boosting the output voltage.

The SM8121A features a built-in soft-start function. The soft-start time is approximately 500µs from after the chip enable input CE rising edge. During this interval, the maximum duty is restricted to 50%.

Selecting the Current-setting Resistor (R1)

The SM8121A control stabilizes the voltage on pin FB (0.5V typ.). Hence, the current-setting resistor R1 connected between FB and VSS sets the LED current I_{LED} , where the resistance R1 is given by the following equation.

$$R1 = 0.5 / I_{LED}$$

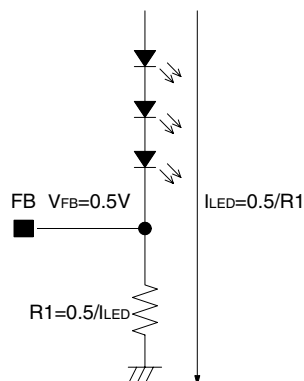

Selecting the Inductor (L)

The recommended inductance for use with the SM8121A is 10 μ H. The inductor DC resistance affects the power efficiency, therefore a low DC resistance inductor is recommended. Note also that the peak inductor current I_{peak} should not exceed the inductor maximum current rating. In pulsed current mode control, the peak inductor current I_{peak} is given by the following equation.

$$I_{\text{peak}} = (V_{\text{IN}} \times T_{\text{ON}}) / L$$

For example, if the input voltage V_{IN} is 3.6V, the inductance L is 10 μ H, and the SW-Tr ON time T_{ON} is 1MHz \times 75% = 0.75 μ s, then the peak inductor current I_{peak} is $(3.6 \times 0.75 \times 10^{-6}) / (10 \times 10^{-6}) = 0.27\text{A} = 270\text{mA}$.

Selecting the Capacitors (C_{IN} , C_{OUT})

The recommended capacitances for use with the SM8121A are 4.7 μ F ceramic input capacitor C_{IN} and 1.0 μ F ceramic output capacitor C_{OUT} . The capacitor ESR ratings affect the ripple voltage, therefore capacitors with low ESR rating are recommended. The input capacitor should be mounted close to the SM8121A IC. Note that the capacitor voltage ratings should be selected to provide sufficient margin for the applied input and output voltages.

For example, if a lithium-ion battery (2.5 to 4.5V) is connected to the input and 3 white LEDs connected in series at the output draw 20mA, then the maximum input voltage is 4.5V and the maximum output voltage is $(4.0\text{V} \times 3 \text{ LEDs}) + 0.5\text{V} = 12.5\text{V}$. Therefore, the input capacitor should have a voltage rating of 6V, and the output capacitor should have a voltage rating of 16V.

Selecting the Rectifier Schottky Barrier Diode (SBD)

The rectifier schottky barrier diode forward-direction voltage drop affects the power efficiency, therefore a Schottky barrier diode with low forward-direction voltage drop is recommended. Note that the diode should be selected to provide sufficient margin for the rated current and reverse-direction withstand voltage.

Board Layout Notes

The following precautions should be followed for stable device operation.

- The inductor L and Schottky barrier diode SBD should be connected close to the pin SW using thick, short circuit wiring.
- The input capacitor C_{IN} should be mounted close to the IC.
- The IC supply voltage V_{DD} wiring and inductor supply wiring should be isolated, reducing any common impedances.
- The ground wiring should be connected at a single point, reducing any common impedances.

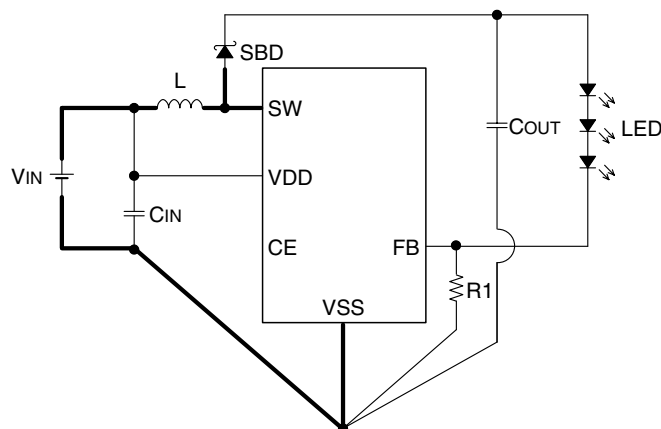

LED OPEN-CIRCUIT PROTECTION

When there is no load (LED open-circuit), the FB pin is pulled-down and then switching occurs at maximum duty. Consequently, the output voltage continues to be boosted and the SW pin voltage may exceed the maximum rating of 27V. A zener diode can be added so that it acts as the output load when the LED is open-circuit, preventing the SW voltage from rising. The zener diode must be selected so that the zener does not breakdown during normal operation. The zener voltage V_{ZD} range is given by the following relationship, where N is the number of LEDs connected in series, V_{FMAX} is the maximum LED forward-bias voltage drop, V_{OUTMAX} is the SW pin maximum output voltage, V_{FB} is the FB pin voltage, and V_{SBD} is the Schottky-barrier diode forward-bias voltage drop.

$$(V_{FMAX} \times N) \leq V_{ZD} \leq (V_{OUTMAX} - V_{FB} - V_{SBD})$$

When the load is applied using a connector (SM8121A and LEDs on separate boards), the zener diode should be mounted on the same board as the SM8121A device so that the SW boost prevention function can operate when the load is disconnected.

Zener Diode (ZD) Only Connection

When the load is removed (LEDs open circuit), the output voltage is determined by the zener voltage, and the output current is determined by the output current-setting resistance. Consequently, the output current when the load is removed is not limited, and thus the input current cannot be controlled.

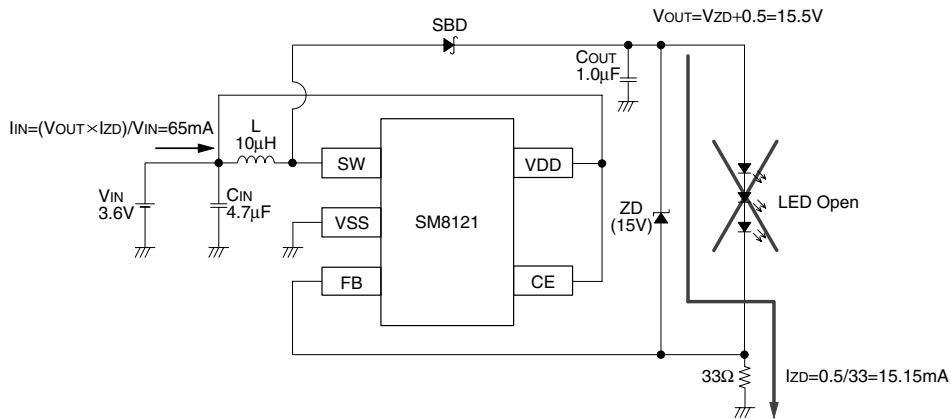

Zener Diode (ZD) and Current-Limiting Resistance Connection

When the load is removed (LEDs open circuit), the output voltage is determined by the zener voltage, and the output current is determined by the sum of the output current-setting resistance and the current-limiting resistance. Consequently, the output current is limited when the load is removed, and the input current can be controlled.

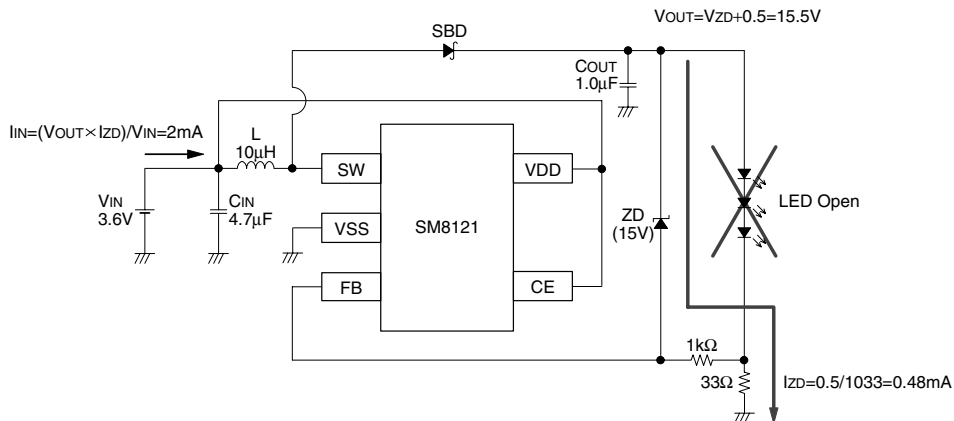

BRIGHTNESS ADJUSTMENT

Brightness Adjustment using FB Pin

The LED brightness can be adjusted using an input DC control voltage connected through resistor R3 to the FB pin. Alternatively, the brightness can be controlled by a PWM signal by adding a low-pass filter comprising resistor R4 and capacitor C1. The PWM signal frequency range is determined by the low-pass filter coefficients. For example, the recommended values for resistor R4 (50kΩ) and capacitor C1 (0.1μF) provide a PWM signal frequency range of 1kHz to 1MHz.

Brightness adjustment using FB pin (DC voltage input)

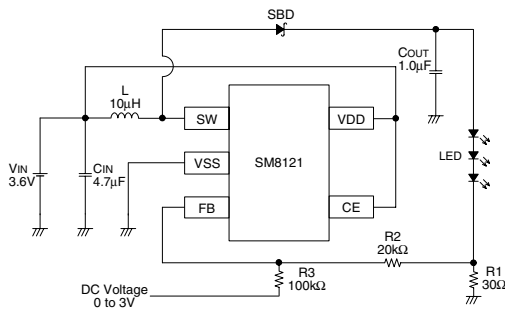

Brightness adjustment circuit using FB pin
(DC voltage input)

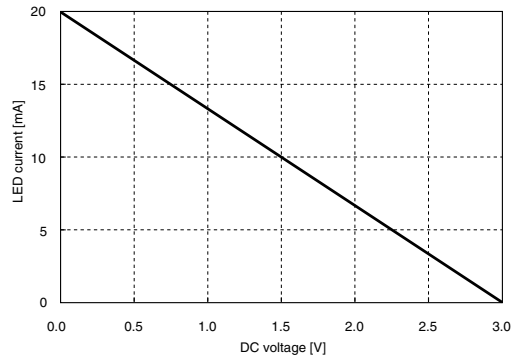

DC voltage vs. LED current

When the brightness is controlled by DC voltage (V_{DC}) connected to resistor R3, the LED current (I_{LED}) is given by equation 1.

$$I_{LED} = \frac{V_{FB} - \frac{R_2 \times (V_{DC} - V_{FB})}{R_3}}{R_1} \quad \dots (1)$$

If the values $R_1 = 30\Omega$, $R_2 = 20k\Omega$, $R_3 = 100k\Omega$, $V_{FB} = 0.5V$, and $V_{DC} = 0V$ are inserted in equation 1, the LED current $I_{LED} = 20mA$, as shown in equation 2.

$$I_{LED} = \frac{0.5 - \frac{20,000 \times (0 - 0.5)}{100,000}}{30} = \frac{0.6}{30} = 20mA \quad \dots (2)$$

If the values $R_1 = 30\Omega$, $R_2 = 20k\Omega$, $R_3 = 100k\Omega$, $V_{FB} = 0.5V$, and $V_{DC} = 3V$ are inserted in equation 1, the LED current $I_{LED} = 0mA$, as shown in equation 3.

$$I_{LED} = \frac{0.5 - \frac{20,000 \times (3 - 0.5)}{100,000}}{30} = \frac{0}{30} = 0mA \quad \dots (3)$$

Taking the above diagram as an example, inserting the values $R_1 = 30\Omega$, $R_2 = 20k\Omega$, $R_3 = 100k\Omega$, $V_{FB} = 0.5V$, and $V_{DC} = 0$ to $3V$ into equation 1 gives the maximum LED current I_{LED} of 20mA when $V_{DC} = 0V$ (equation 2) and the minimum LED current I_{LED} of 0mA when $V_{DC} = 3V$ (equation 3).

Brightness adjustment using FB pin (PWM signal input)

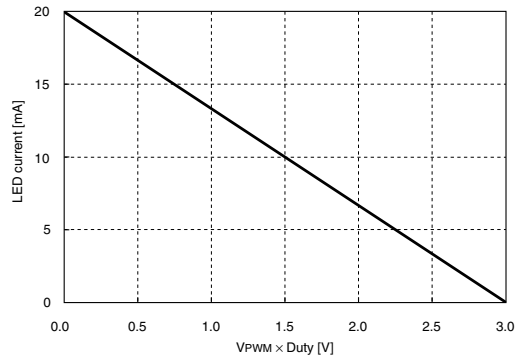
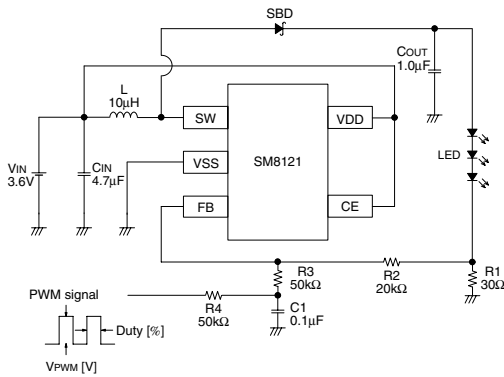

Brightness adjustment circuit using FB pin (PWM signal input)

PWM signal vs. LED current

When the brightness is controlled by PWM signal ($V_{PWM} \times \text{Duty}$), the LED current (I_{LED}) is given by equation 4.

$$I_{LED} = \frac{V_{FB} - \frac{R_2 \times (V_{PWM} \times \text{Duty} - V_{FB})}{R_3 + R_4}}{R_1} \quad \dots (4)$$

If the values $R_1 = 30\Omega$, $R_2 = 20k\Omega$, $R_3 = 50k\Omega$, $R_4 = 50k\Omega$, $V_{FB} = 0.5V$, $V_{PWM} = 3V$, and $\text{Duty} = 0\%$ are inserted in equation 4, the LED current $I_{LED} = 20mA$, as shown in equation 5.

$$I_{LED} = \frac{0.5 - \frac{20,000 \times (3 \times 0 - 0.5)}{50,000 + 50,000}}{30} = \frac{0.6}{30} = 20mA \quad \dots (5)$$

If the values $R_1 = 30\Omega$, $R_2 = 20k\Omega$, $R_3 = 50k\Omega$, $R_4 = 50k\Omega$, $V_{FB} = 0.5V$, $V_{PWM} = 3V$, and $\text{Duty} = 100\%$ are inserted in equation 4, the LED current $I_{LED} = 0mA$, as shown in equation 6.

$$I_{LED} = \frac{0.5 - \frac{20,000 \times (3 \times 1 - 0.5)}{50,000 + 50,000}}{30} = \frac{0}{30} = 0mA \quad \dots (6)$$

Taking the above diagram as an example, inserting the values $R_1 = 30\Omega$, $R_2 = 20k\Omega$, $R_3 = 50k\Omega$, $R_4 = 50k\Omega$, $V_{FB} = 0.5V$, $V_{PWM} = 3V$, and $\text{Duty} = 0$ to 100% into equation 4 gives the maximum LED current I_{LED} of $20mA$ when $\text{Duty} = 0\%$ (equation 5) and the minimum LED current I_{LED} of $0mA$ when $\text{Duty} = 100\%$ (equation 6).

Brightness Adjustment using CE Pin

The LED average current can be adjusted by controlling the duty of a PWM signal input on the CE pin. When CE goes from LOW to HIGH, the soft start function operates (with 500µs constant soft start time) and, therefore, the LED average current ratio for a given PWM signal duty falls with increasing PWM signal frequency. Taking this into consideration, the recommended PWM control signal has a frequency range of 100 to 400Hz with duty cycle range of 10 to 90%.

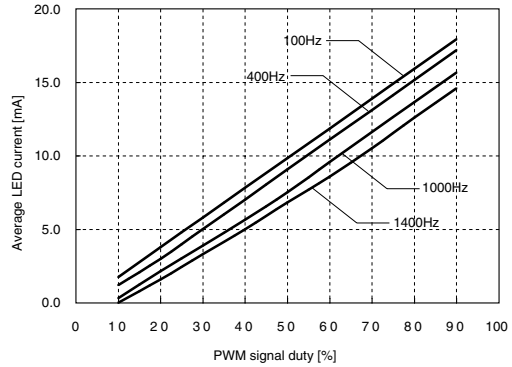
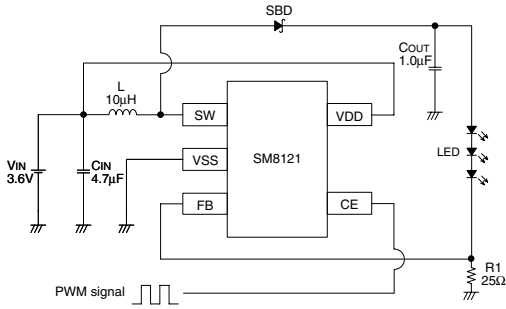

Brightness adjustment circuit using CE pin

PWM signal duty vs. LED average current

When adjusting the brightness using the CE pin, a ripple voltage synchronized to the PWM signal is generated across the output capacitor C_{OUT} . The amplitude of the ripple voltage is determined by the number of LEDs and their forward-bias voltage drop characteristics. If a ceramic capacitor is used for the output capacitor C_{OUT} , an audible noise may be generated due to the ceramic capacitor's piezoelectric effect. The audible noise level depends on the ceramic capacitor (capacitance, bias dependency, withstand voltage etc.), LEDs (number, forward-bias voltage drop etc.), and mounting board (thickness, mounting conditions etc.), and thus should be verified under actual conditions.

Alternatively, a tantalum capacitor or film capacitor with low piezoelectric effect can be used as the output capacitor C_{OUT} to minimize the noise level, or the brightness can be adjusted using the FB pin as described earlier. The audible noise generated when using the CE pin is not an inherent phenomena of the SM8121A device, but of the brightness adjustment method employed.

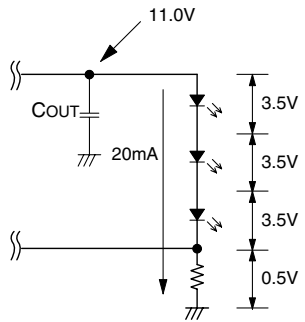

Output voltage with LEDs ON

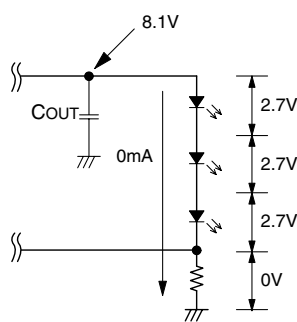

Output voltage with LEDs OFF

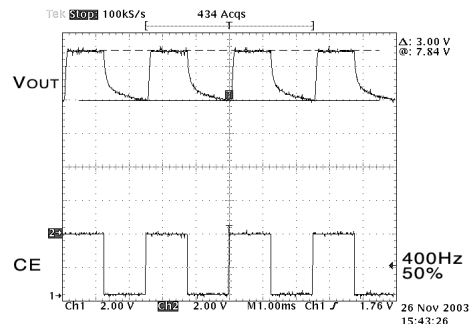

CE input signal and output ripple voltage

Current Switching using External Transistors

If only a few brightness steps are required, the LED current can be adjusted by switching the LED current setting resistance using external transistors (Tr).

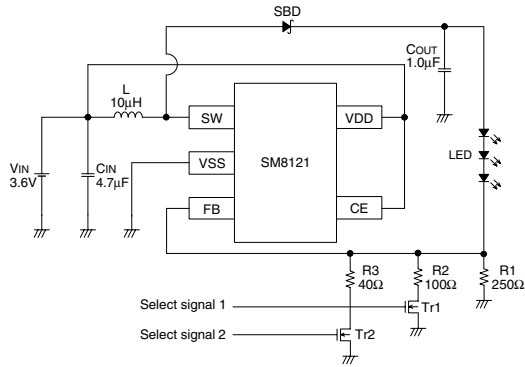

Select signal 2	Select signal 1	I_{LED}
Low	Low	2mA
Low	High	2 + 5 = 7mA
High	Low	2 + 12.5 = 14.5mA
High	High	2 + 5 + 12.5 = 19.5mA

TYPICAL APPLICATION CIRCUITS

2 LEDs

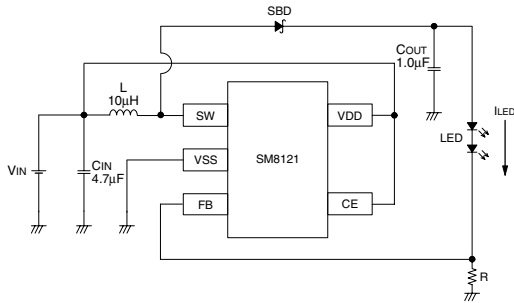

C_{IN}: 2012Y5VIC 475Z (TDK)
 C_{OUT}: 2012Y5VIH 105Z (TDK)
 L: LQH32CN100K11 (Murata)
 SBD: RB551V-30 (ROHM)
 LED: NSCW455 (NICHIA)

3 LEDs

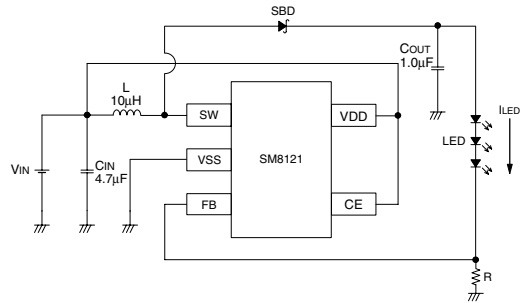

C_{IN}: 2012Y5VIC 475Z (TDK)
 C_{OUT}: 2012Y5VIH 105Z (TDK)
 L: LQH32CN100K11 (Murata)
 SBD: RB551V-30 (ROHM)
 LED: NSCW455 (NICHIA)

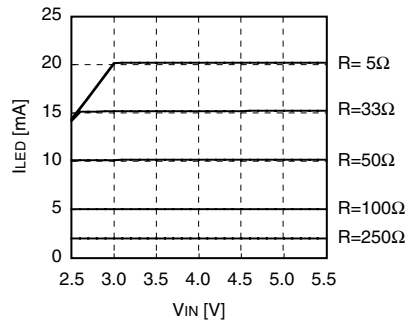
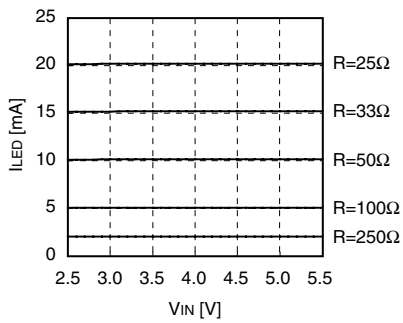
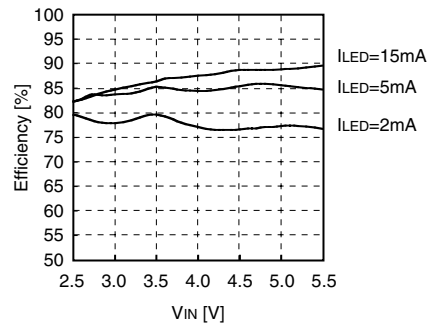
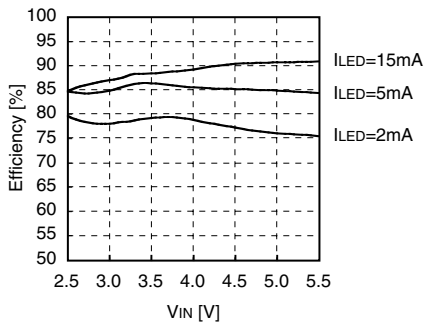
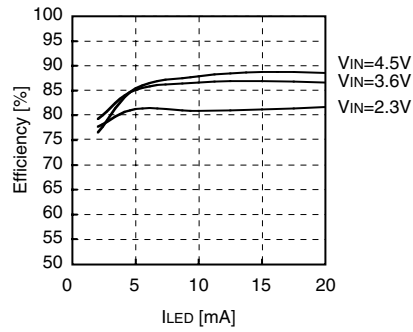
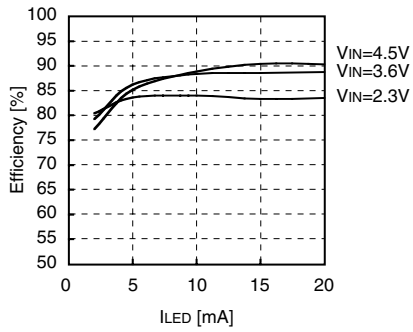

4 LEDs

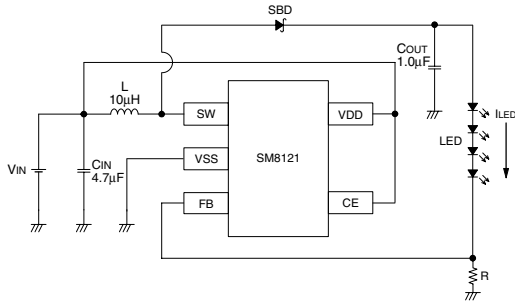

C_{IN}: 2012Y5VIC 475Z (TDK)
 C_{OUT}: 2012Y5VIH 105Z (TDK)
 L: LQH32CN100K11 (Murata)
 SBD: RB551V-30 (ROHM)
 LED: NSCW455 (NICHIA)

5LEDs

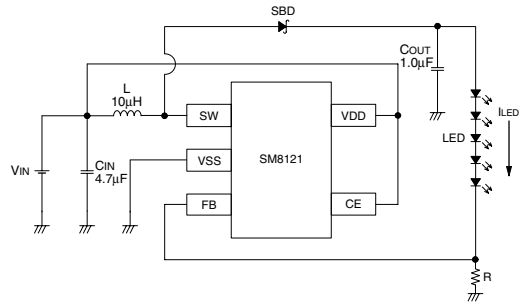

C_{IN}: 2012Y5VIC 475Z (TDK)
 C_{OUT}: 2012Y5VIH 105Z (TDK)
 L: LQH32CN100K11 (Murata)
 SBD: RB551V-30 (ROHM)
 LED: NSCW455 (NICHIA)

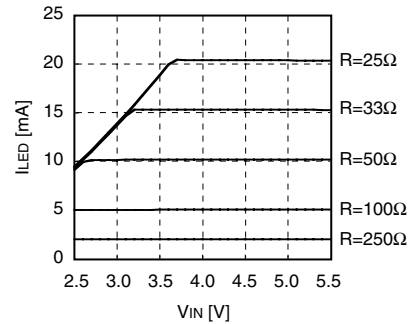
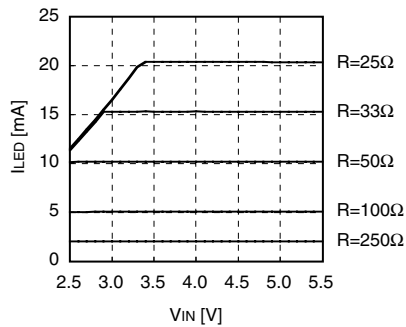
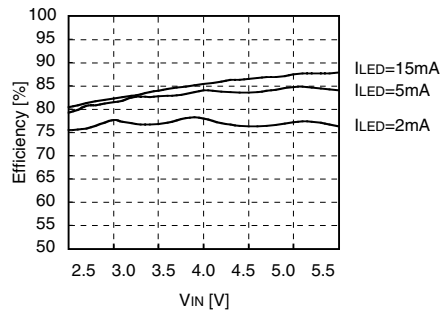
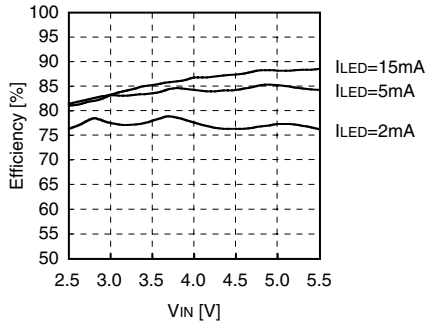
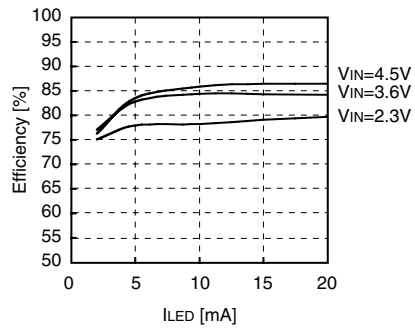
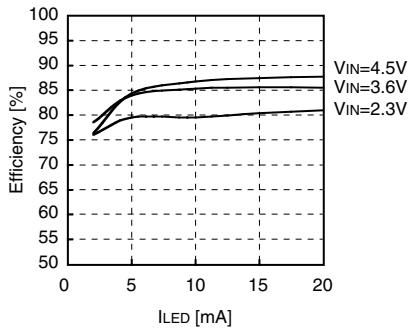

6 LEDs

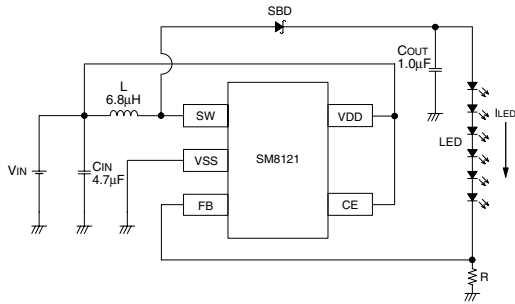

C_{IN} : 2012Y5VIC 475Z (TDK)
 C_{OUT} : 2012Y5VIH 105Z (TDK)
 L: LQH3N6R8K34 (Murata)
 SBD: RB551V-30 (ROHM)
 LED: NSCW455 (NICHIA)

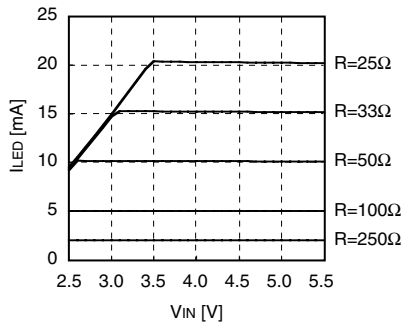
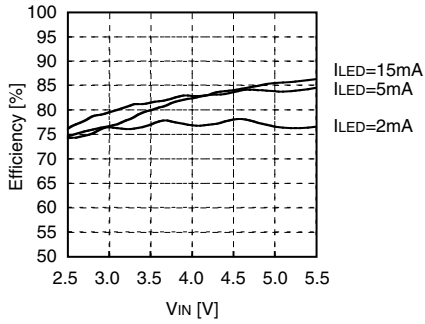
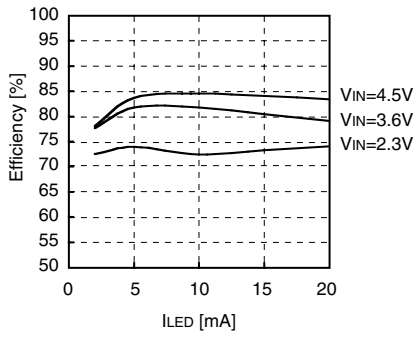

EVALUATION BOARD PATTERN

SOT23-5 package

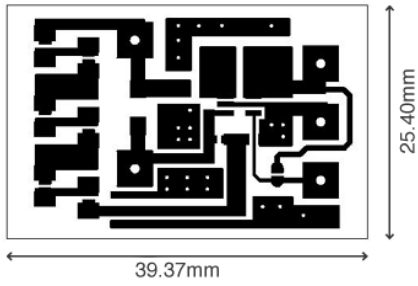

Pattern + Hole (Top view)

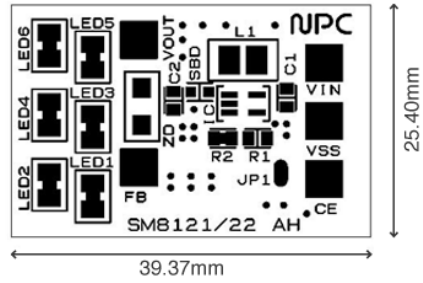

Silk + Resist (Top view)

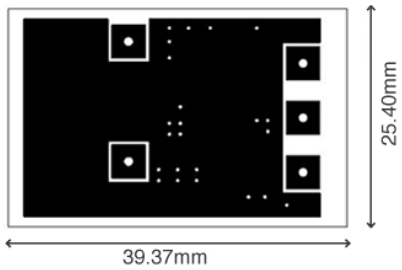

Pattern + Hole (Bottom view)

FOOTPRINT PATTERN

SOT23-5

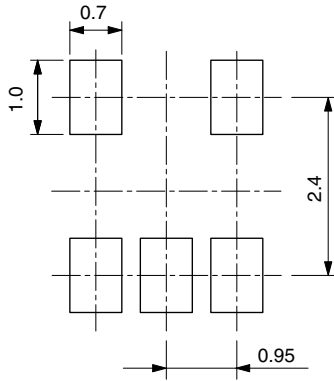

Please pay your attention to the following points at time of using the products shown in this document.

1. The products shown in this document (hereinafter "Products") are designed and manufactured to the generally accepted standards of reliability as expected for use in general electronic and electrical equipment, such as personal equipment, machine tools and measurement equipment. The Products are not designed and manufactured to be used in any other special equipment requiring extremely high level of reliability and safety, such as aerospace equipment, nuclear power control equipment, medical equipment, transportation equipment, disaster prevention equipment, security equipment. The Products are not designed and manufactured to be used for the apparatus that exerts harmful influence on the human lives due to the defects, failure or malfunction of the Products. If you wish to use the Products in that apparatus, please contact our sales section in advance.
In the event that the Products are used in such apparatus without our prior approval, we assume no responsibility whatsoever for any damages resulting from the use of that apparatus.
2. NPC reserves the right to change the specifications of the Products in order to improve the characteristics or reliability thereof.
3. The information described in this document is presented only as a guide for using the Products. No responsibility is assumed by us for any infringements of patents or other rights of the third parties which may result from its use. No license is granted by implication or otherwise under any patents or other rights of the third parties. Then, we assume no responsibility whatsoever for any damages resulting from that infringements.
4. The constant of each circuit shown in this document is described as an example, and it is not guaranteed about its value of the mass production products.
5. In the case of that the Products in this document falls under the foreign exchange and foreign trade control law or other applicable laws and regulations, approval of the export to be based on those laws and regulations are necessary. Customers are requested appropriately take steps to obtain required permissions or approvals from appropriate government agencies.



SEIKO NPC CORPORATION

1-9-9, Hatchobori, Chuo-ku,
Tokyo 104-0032, Japan
Telephone: +81-3-5541-6501
Facsimile: +81-3-5541-6510
<http://www.npc.co.jp/>
Email:sales@npc.co.jp

ND14009-E-00 2014.06