

OVERVIEW

The CF5762AB0 is an analog chime clock CMOS IC that uses a 4.194304MHz crystal oscillator source. It can play a melody and hour chime when triggered by an hourly signal. It generates output sound using dual pitch synthesis (DPS) to produce high-tone quality melodies and chime signals.

FEATURES

- 4.2MHz fundamental oscillator frequency
- 1.5V and 3.0V supply voltages ($V_{DD} - V_{SS}$)
- 8Hz sweep
- Melody switching function (SEL1 and SEL2)
 - choice of 4 melodies played hourly
- Chime output using time detection circuit
- Dual pitch synthesis (DPS) sound generator
- BTL-configuration melody output circuit
- 2 simultaneous output pitches
- Busy (play) signal control output (ATN)
- Melody stop when dark (CDS and CO4N)
 - melody stop using an external CdS element
- Melody stop at night (AMI and PMI)
- Reset function
- Chattering elimination function

PAD LAYOUT

(Unit: mm)

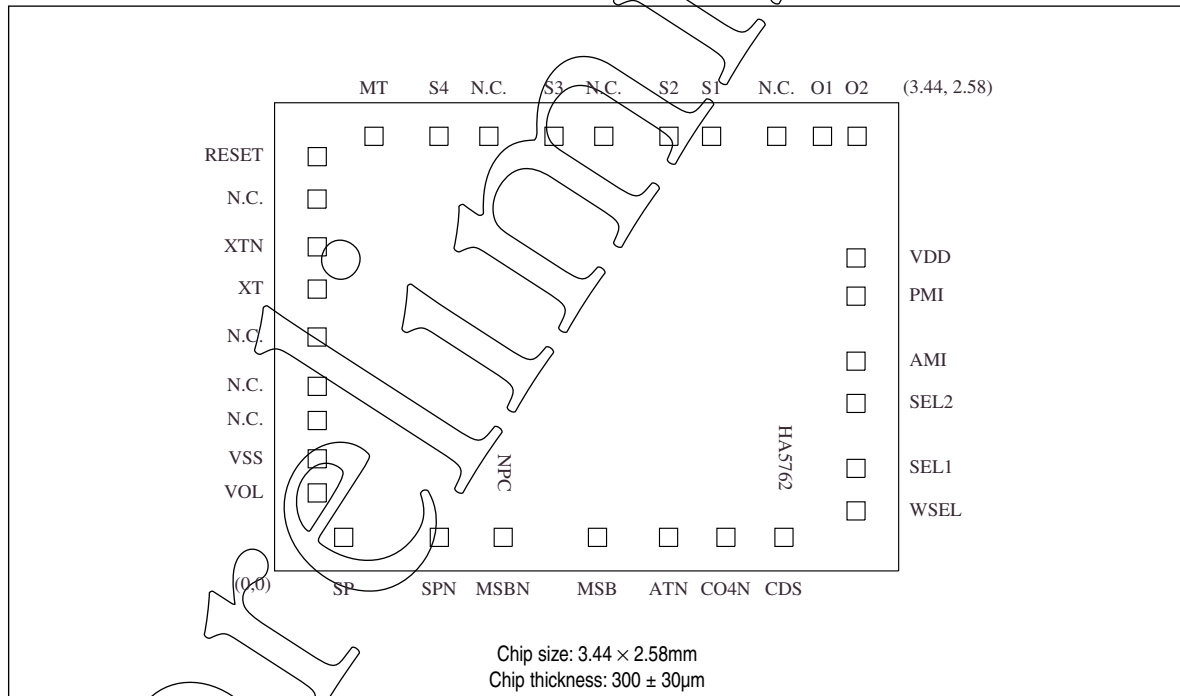

PAD DESCRIPTION/DIMENSIONS

Name	Description	Input/output	Dimensions (μm)	
			X	Y
RESET	Reset input	Input with pull-down	235	2283
NC	No connection (leave open circuit)		234	2049
XTN	Oscillator output		235	1786
XT	Oscillator input		235	1553
NC	No connection (leave open circuit)		234	1289
NC	No connection (leave open circuit)		235	1017
NC	No connection (leave open circuit)		235	829
VSS	0V supply		235	618
VOL	Volume adjust input	Resistance connection input	235	430
SP	Audio output (9-bit current output D/A)	P-channel output	381	185
SPN	Audio output (9-bit current output D/A)	P-channel output	908	185
MSBN	Audio output (sign bit)	CMOS output	1260	185
MSB	Audio output (sign bit)	CMOS output	1780	185
ATN	Control signal output	CMOS output	2172	185
CO4N	Melody stop when dark (CdS) output	CMOS output	2488	185
CDS	Melody stop when dark (CdS) input	Input with pull-up when inactive	2808	185
WSEL	Waveform select input	Input with pull-down	3205	331
SEL1	Melody select input 1	Input with pull-down	3205	565
SEL2	Melody select input 2	Input with pull-down	3205	923
AMI	Melody stop at night input	Input with pull-down	3205	1156
PMI	Melody stop at night input	Input with pull-down	3205	1514
VDD	1.5V supply (IC substrate)		3205	1725
O2	Clock movement motor drive output 2	CMOS output	3211	2395
O1	Clock movement motor drive output 1	CMOS output	3020	2395
NC	No connection (leave open circuit)		2768	2395
S1	Time detect input 1	Input with pull-down	2409	2395
S2	Time detect input 2	Input with pull-down	2174	2395
NC	No connection (leave open circuit)		1815	2395
S3	Time detect input 3	Input with pull-down	1540	2395
NC	No connection (leave open circuit)		1181	2395
S4	Time detect input 4	Input with pull-down	906	2395
MT	Hourly signal input	Input with pull-down	548	2395

SPECIFICATIONS

Absolute Maximum Ratings

Parameter	Symbol	Condition	Rating	Unit
Supply voltage range	$V_{DD} - V_{SS}$		-0.3 to 5.0	V
Input voltage range	V_{IN}		V_{SS} to V_{DD}	V
Storage temperature range	T_{stg}		-65 to 150	°C
Operating temperature range	T_{opr}		-30 to 80	°C

Electrical Characteristics

$V_{DD} = 1.5V$, $V_{SS} = 0V$, $T_a = 25^\circ C$, $f_0 = 4.194304MHz$, $C_1 = 150\Omega$, $C_G = C_D = 15pF$ unless otherwise noted

Parameter	Symbol	Condition	Rating			Unit
			min	typ	max	
Minimum operating voltage ¹	$V_{DD} (min)$	$f_{OSC} \approx f_0$	-	1.2		V
Maximum operating voltage ¹	$V_{DD} (max)$	$f_{OSC} \approx f_0$	3.6	-	-	V
Operating current consumption (non-play mode) ¹	I_{DD1}	$f_{OSC} \approx f_0$, outputs open	-	20	50	μA
Operating current consumption (play mode) ¹	I_{DD2}	$f_{OSC} \approx f_0$, outputs open	-	60	150	μA
Oscillator start-up time ¹	t_1	$f_{OSC} \approx f_0$, $V_{DD} = 1.2V$	-	-	5.0	s
Frequency-voltage characteristic ²	ϵ_1, ϵ_2	$f_{OSC} (1.5V)$	-	-	2.0	ppm
Output saturation resistance ³	R_{out}	$V_{DD} = 1.2V, R_L = 400\Omega$	-	70	100	Ω
Input current 1 (MT, RESET, WSEL, SEL1, SEL2, AMI, PMI) ⁴	I_{IH1}	$V_{DD} = 1.5V, V_{IH} = 1.5V$	0.4	1.0	2.0	μA
Input current 2 (S1 to S4) ⁴	I_{IH2}	$V_{DD} = 1.5V, V_{IH} = 1.5V$	1.0	2.0	4.0	μA
Input current 3 (CDS) ⁴	I_{IL3}	$V_{DD} = 1.5V, V_{IL} = 0V$	1.0	2.0	4.0	μA
Output current 1 (CO4N) ⁵	I_{OL1}	$V_{DD} = 1.2V, V_{OL} = 0.2V$	200	500	1000	μA
	I_{OH1}	$V_{DD} = 1.2V, V_{OH} = 0.2V$	200	500	1000	μA
Output current 2 (ATN) ⁵	I_{OL2}	$V_{DD} = 1.2V, V_{OL} = 0.2V$	200	500	1000	μA
	I_{OH2}	$V_{DD} = 1.2V, V_{OH} = 1.0V$	50	100	200	μA
Output current 3 (MSB, MSBN) ⁵	I_{OL3}	$V_{DD} = 1.2V, V_{OL} = 0.6V$	1.5	-	-	mA
	I_{OH3}	$V_{DD} = 1.2V, V_{OH} = 0.6V$	1.5	-	-	mA
Output current 4 (SP, SPN) ⁵	I_{OH4}	$V_{DD} = 1.2V, V_{OH} = 0.6V$	0.7	1.0	1.3	mA
Volume 0 resistance ⁶	R_{VOL0}	$V_{DD} = 1.5V$	40	45	50	k Ω
External capacitance (XT1)	C_G		5	15	36	pF
External capacitance (XTN)	C_D		5	15	36	pF

1. Measured using "Measurement Circuit" with $f_{OSC} \approx f_0 \pm 30ppm$, functions auto-start normally.

$$2. \epsilon_1 = \epsilon (1.2V) = \frac{|f(1.2V) - f(1.5V)|}{f(1.5V)}$$

$$\epsilon_2 = \epsilon (1.7V) = \frac{|f(1.7V) - f(1.5V)|}{f(1.5V)}$$

3. Load resistor R_L connected between outputs O1 and O2. If V_{OUT} is the voltage wave maximum value across the resistor, then R_{out} is given by:

$$R_{out} = \frac{(V_{DD} / V_{OUT} - 1) \times R_L}{1} = (1.2V / V_{OUT} - 1) \times 400(\Omega)$$

4. The I_{IH} and I_{IL} ratings are for each input when short circuited to V_{DD} or V_{SS} . I_{IL1} is the current when CDS is inactive (when CO4N output is HIGH).

5. Output current (I_{OL} , I_{OH}) measured using the following circuit. I_{OH4} is measured with a $10k\Omega$ resistor connected to VOL.

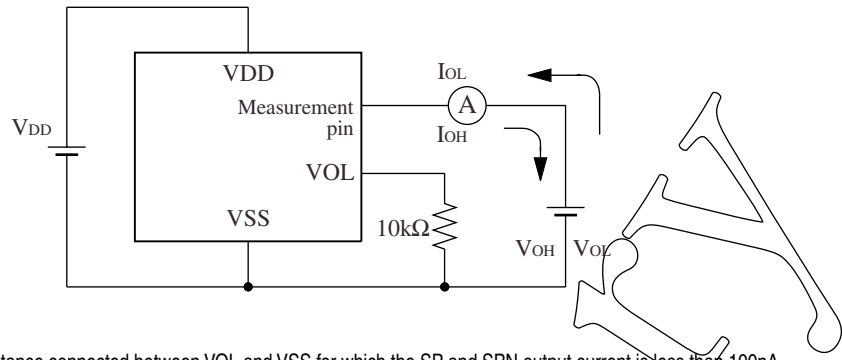

6. Volume 0 resistance is the resistance connected between VOL and VSS for which the SP and SPN output current is less than 100nA.

Measurement Circuit

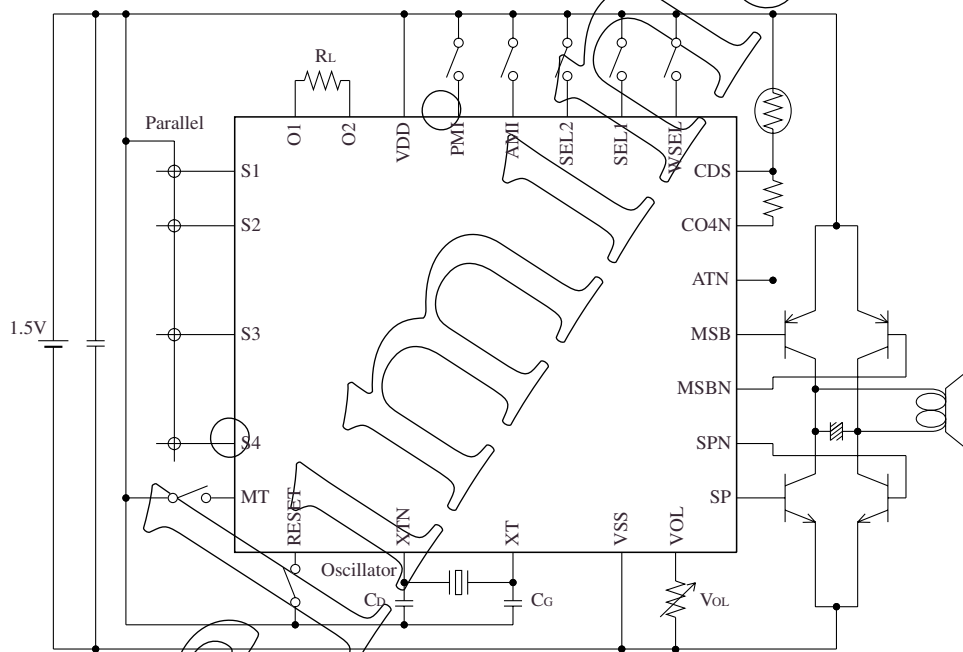

$f_0 = 4.194304\text{MHz}$, $C_G = 15\text{pF}$, $C_D = 15\text{pF}$, $R_L = 400\Omega$, $V_{OL} = 50k\Omega$

FUNCTIONAL DESCRIPTION

Motor Output

Sweep movement frequency: 8Hz

The pulse cycle (T_{cy}) and the pulsewidth (T_{pw}) correspond to 1/16 Sec (= 62.5ms).

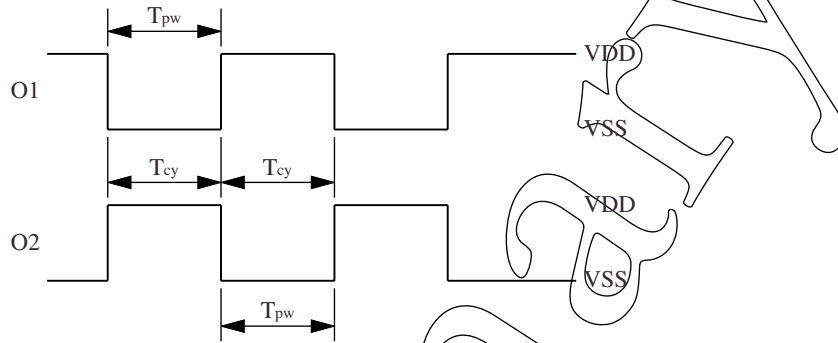

Figure 1. Motor pulse output

Reset

All functions are reset when RESET goes HIGH. The reset is released when RESET goes LOW or open circuit (RESET has a built-in pull-down resistor).

Clock movement reset

For step clock movement, the seconds are stopped. When reset is released, the next pulse is output on the opposing output pin to that immediately before the reset was applied. The time delay until the pulse output after reset is released is $1 + \frac{0.0625}{0}$ seconds.

For sweep clock movement, both outputs O1 and O2 are held HIGH during reset.

Melody reset

If a reset occurs during melody or chime output, the output stops immediately. During reset, the MT is valid when it is input. When the MT pin is HIGH, the reset signal is valid if input.

Time reset

During the timing between reset and the hourly signal input when the melody select pins (SEL1, SEL2) are used to monitor, chime monitoring is inactive while melody monitoring is active.

Chattering Elimination

Input	Description
S1 to S4, CDS, WSEL	No chattering elimination function
MT, RESET	If the input goes HIGH and continues for 2 or more 16Hz cycles, then the input is recognized, otherwise it is ignored. If the input goes LOW, it is sampled at 16Hz.
AMI, PMI	If the input changes state and continues for 2 or more 16Hz cycles, then the input is recognized, otherwise it is ignored.
SEL1, SEL2	The inputs are sampled periodically at 16Hz. If either SEL1 or SEL2 changes state, the state is held for 62.5ms and then the state of both SEL1 and SEL2 are read. If either SEL1 or SEL2 changes state during this interval, a further interval of 62.5ms is added before reading the input states (see figure 2).

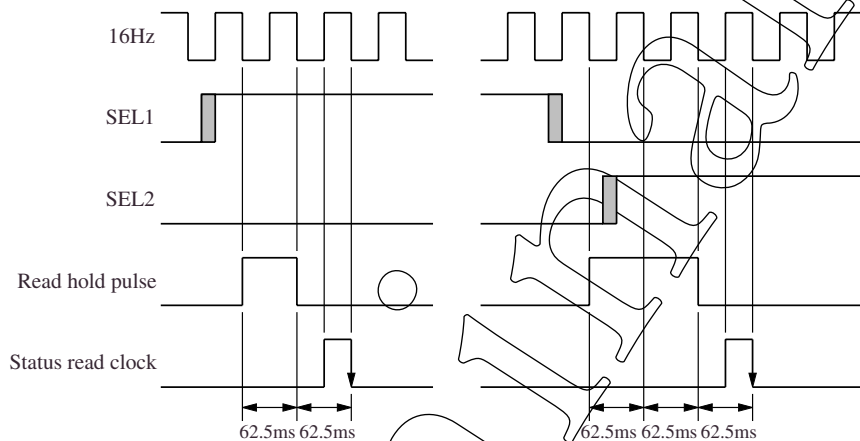

Figure 2. SEL1, SEL2 read timing

Power-ON Initialization

When power is applied, the following reset functions take place.

- Clock movement motor outputs (O1, O2)
After the oscillator starts, each output is activated with O1 being LOW and O2 being HIGH.
- Reset (RESET)
After power is applied, a 62.5ms reset pulse is output. If, however, RESET is HIGH when power is applied, the corresponding reset state is recognized as-is.
- Melody trigger (MT)
If MT is HIGH when power is applied, melody output stops. Melody output starts when MT goes LOW and then goes HIGH again.
- Time information (S1 to S4)
The time data is reset to a zero state not representing any hour in the range 1 to 12 o'clock, and the inputs are not read until the next hourly signal input.
- Melody switching function (SEL1, SEL2)
When power is applied, the input states are reset and then immediately read in.
- Melody stop at night (AMI, PMI)
When power is applied, the PM flag is set to LOW (AM setting) and then, immediately, the input states are read in. If at this time both AMI and PMI are HIGH, then the PM flag stays set to LOW.

MELODY FUNCTION DESCRIPTION

Melodies

There are 4 melodies stored, and which can be played hourly.

Time Function

If the following conditions are satisfied when a HIGH-level hourly signal is input on MT, then hourly melody output occurs. The hourly melody is a combination of melody output and subsequent chime signals. MT has a built-in pull-down resistor.

The number of chimes played are determined by time detection in 12-hour mode.

<Melody conditions>

1. The hourly signal turns OFF once before turning ON
2. Melody stop at night function is not set for current time interval (see "Melody Stop at Night")
3. Melody stop when dark function is not active (see "Melody Stop when Dark")

If S1 to S4 are all HIGH (no chime), then condition number 2 is ignored. If the time information inputs change state and an hourly signal on MT is input during melody output, the output stops and then starts again under the new conditions.

Melody Select Switching

The melody to be played is selected by the state of SEL1 and SEL2. SEL1 and SEL2 have built-in pull-down resistors.

<Melody switch function>

SEL1	SEL2	Melody (hourly signal)
LOW	LOW	Melody 1 + chime
HIGH	LOW	Melody 2 + chime
LOW	HIGH	Melody 3 + chime
HIGH	HIGH	Melody 4 + chime

Time Detection

The time information inputs are only read when the hourly signal is input on MT. At all other times the internal data does not change, even if the time information inputs change state. The hours 1 through 12 are represented in 12-hour mode with an internal PM flag. The PM flag reverses state when the hour switches from 11 to 12, or from 12 to 11 if the time setting is being reversed to adjust to the correct time.

When the S1 to S4 inputs are all HIGH, the melody output plays without chimes. These inputs determine the time detection and are read into internal registers when the hourly signal is input on MT. Other input combinations not shown are invalid. S1 to S4 have built-in pull-down resistors.

S4	S3	S2	S1	Time
LOW	LOW	LOW	HIGH	1 o'clock
LOW	LOW	HIGH	LOW	2 o'clock
LOW	LOW	HIGH	HIGH	3 o'clock
LOW	HIGH	LOW	LOW	4 o'clock
LOW	HIGH	LOW	HIGH	5 o'clock
LOW	HIGH	HIGH	LOW	6 o'clock
LOW	HIGH	HIGH	HIGH	7 o'clock
HIGH	LOW	LOW	LOW	8 o'clock
HIGH	LOW	LOW	HIGH	9 o'clock
HIGH	LOW	HIGH	LOW	10 o'clock
HIGH	LOW	HIGH	HIGH	11 o'clock
HIGH	HIGH	LOW	LOW	12 o'clock
LOW	LOW	LOW	LOW	No change
HIGH	HIGH	HIGH	HIGH	No chime

Melody Stop at Night

The melody output can be disabled at night by the state of AMI and PMI. This function disables the melody output from 11:00PM to 5:45AM, inclusive. AMI and PMI have built-in pull-down resistors.

AMI	PMI	Melody output
LOW	LOW	Always enabled
LOW	HIGH	Disabled during PM hours (PM flag is HIGH)
HIGH	LOW	Disabled during AM hours (PM flag is LOW)
HIGH	HIGH	Always disabled

Note that when used together with the melody stop when dark function, melody output can be disabled by either function.

Melody Stop when Dark

When a CdS element and resistor is connected between CO4N and VDD with the mid-point potential connected to CDS, the CDS input can be used to detect the brightness and to stop melody output when the surroundings become dark.

CDS	Melody output
LOW	Disabled due to darkness
HIGH	Enabled

The CDS input has a built-in pull-up resistor when inactive. This pull-up is switched off when CO4N output is LOW. CO4N goes LOW in response to the hourly signal input on MT signal. The melody play output is then disable/enabled depending on the state of the CDS input.

If this function is not used, the CDS input must be tied HIGH.

Note that when used together with the melody stop at night function, melody output can be disabled by either function.

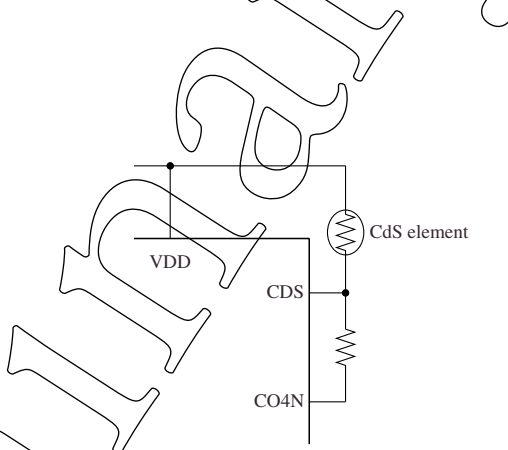

Figure 3. Darkness detection circuit

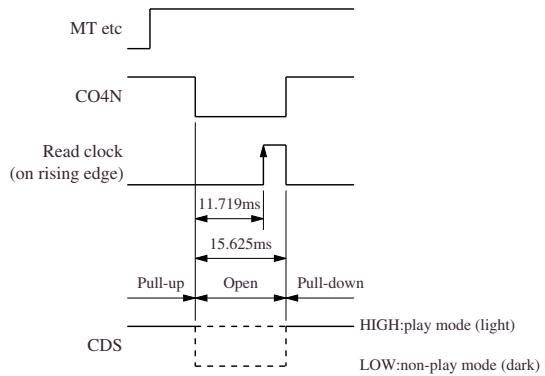

Figure 4. Darkness detection timing

Melody Play Mode

The melody output plays in complete one-shot mode only.

A complete one-shot melody plays through to the end of a whole melody and does not start again as long as the current melody play conditions do not

change, even if the hourly signal is input again. However, if during melody play the melody output stops or other melody start conditions change, the current melody output may stop.

Dual Pitch Synthesis (DPS)

Separate A and B pitches are processed by reading a single set of waveform data at slightly varying frequencies to create a chorus effect, to which an envelope

functions are added, and then the resulting pitches are mixed (added) to generate output pitches.

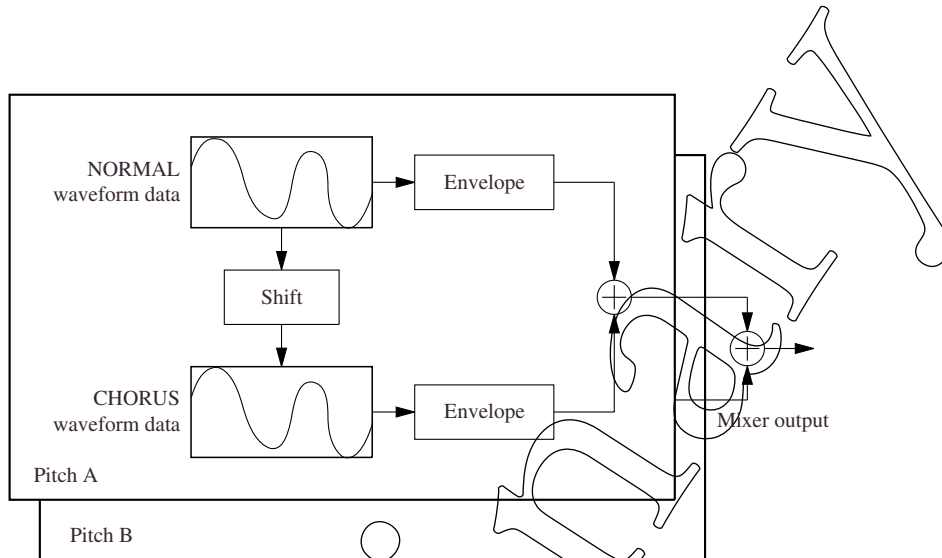

Figure 5. Dual pitch synthesis block diagram

Number of Simultaneous Pitches

There are a maximum of 2 pitches with 2 pitch colors that can be generated simultaneously. These are

the A and B normal melody (normal waveform) and chorus (chorus waveform) pitches.

Dynamic Range

The range of pitches stored in Note-ROM is C3 to C6.

Waveform Data

There are 2 waveform data sets that are stored in Wave-ROM: Wave data 0 and Wave data 1. When WSEL is LOW or open circuit, pitch synthesis uses the preassigned waveform data sets. When WSEL is HIGH, all pitch synthesis uses the wave data 1 set.

If the waveform data assignment is changed mid melody, subsequent pitch sounds generated will change because the data waveform used for pitch synthesis changes immediately in response to WSEL, even during pitch synthesis.

Melody Output Circuit

The melody output circuit employs a BTL configuration.

The D/A converter is a 2-pin (SP and SPN) 9-bit P-channel current adder which, together with MSB and MSBN outputs, is used to drive 4 external transistors

(PNP \times 2, NPN \times 2) which are used to drive a speaker.

In addition, the volume adjust pin (VOL) can be used to adjust the volume by connecting an external 10k Ω resistor between VOL and VSS.

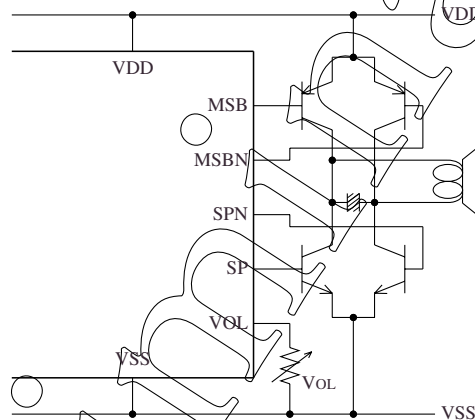

Figure 6. BTL output

Control Signal Output

A LOW-level active busy signal is output from ATN whenever a melody output is playing.

NIPPON PRECISION CIRCUITS INC. reserves the right to make changes to the products described in this data sheet in order to improve the design or performance and to supply the best possible products. Nippon Precision Circuits Inc. assumes no responsibility for the use of any circuits shown in this data sheet, conveys no license under any patent or other rights, and makes no claim that the circuits are free from patent infringement. Applications for any devices shown in this data sheet are for illustration only and Nippon Precision Circuits Inc. makes no claim or warranty that such applications will be suitable for the use specified without further testing or modification. The products described in this data sheet are not intended to use for the apparatus which influence human lives due to the failure or malfunction of the products. Customers are requested to comply with applicable laws and regulations in effect now and hereinafter, including compliance with export controls on the distribution or dissemination of the products. Customers shall not export, directly or indirectly, any products without first obtaining required licenses and approvals from appropriate government agencies.

NPC
NIPPON PRECISION CIRCUITS INC.

NIPPON PRECISION CIRCUITS INC.

4-3, Fukuzumi 2-chome, Koto-ku,
Tokyo 135-8430, Japan
Telephone: +81-3-3642-6661
Facsimile: +81-3-3642-6698
<http://www.npc.co.jp/>
Email: sales@npc.co.jp

NP0014AE 2000.10